



Installation instructions for

Toyota Avensis Verso/Sportsvan all E-Gas models 2001 - 2009



Before installation.

To make the installation easier, the complete installation instruction should be read through, before the installation is started.

This installation instruction, contains information, how to install the E-Cruise, which is not a Do-It-Yourself job. Modern cars are equipped with electronic, which can be costly damaged by inappropriate treatment.

Altendorf GmbH can not be held responsible, for any error caused by wrong installation.

Check that all the parts are included in the kit.

- 1 pcs. Unit.**
- 1 pcs. 14-p connector.**
- 1 pcs. 12-p connector.**
- 1 pcs. 8-p connector.**
- 1 pcs. 2-p connector for OBD.**
- 5 pcs. Cables.**
- 1 pcs. Installation guide.**
- 1 pcs. Owners manual.**
- 1 pcs. Drill template.**
- 1 pcs. Screws for the switch.**

Genuine parts required is not available from EL-PAS.

- 1 pcs. 84632-34011 Control switch.**

Some good advice.

- **Always disconnect the negativ cable from the battery, before installing.**
- **Always use the enclosed installation instruction for installing the E-Cruise.**
- **The rev. number on the unit label and the installation guide must be the same.**
- **Be aware that eg. radio code might has to be typed in.**
- **Find a location to install the unit and control switch.**
- **If any wire(s) left, then cut off and insulate.**
- **Only use multimeter to measure.**
- **Always drive the car for a complete test, before assemble the car.**
- **Flying lead(s) must be soldered.**

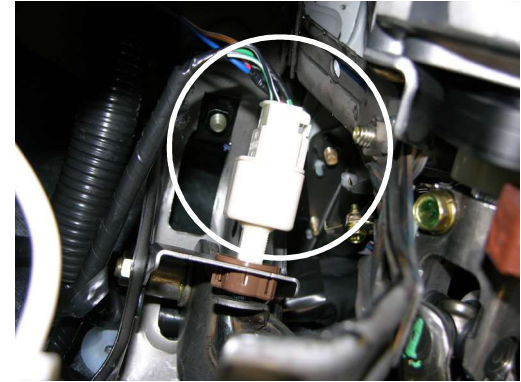
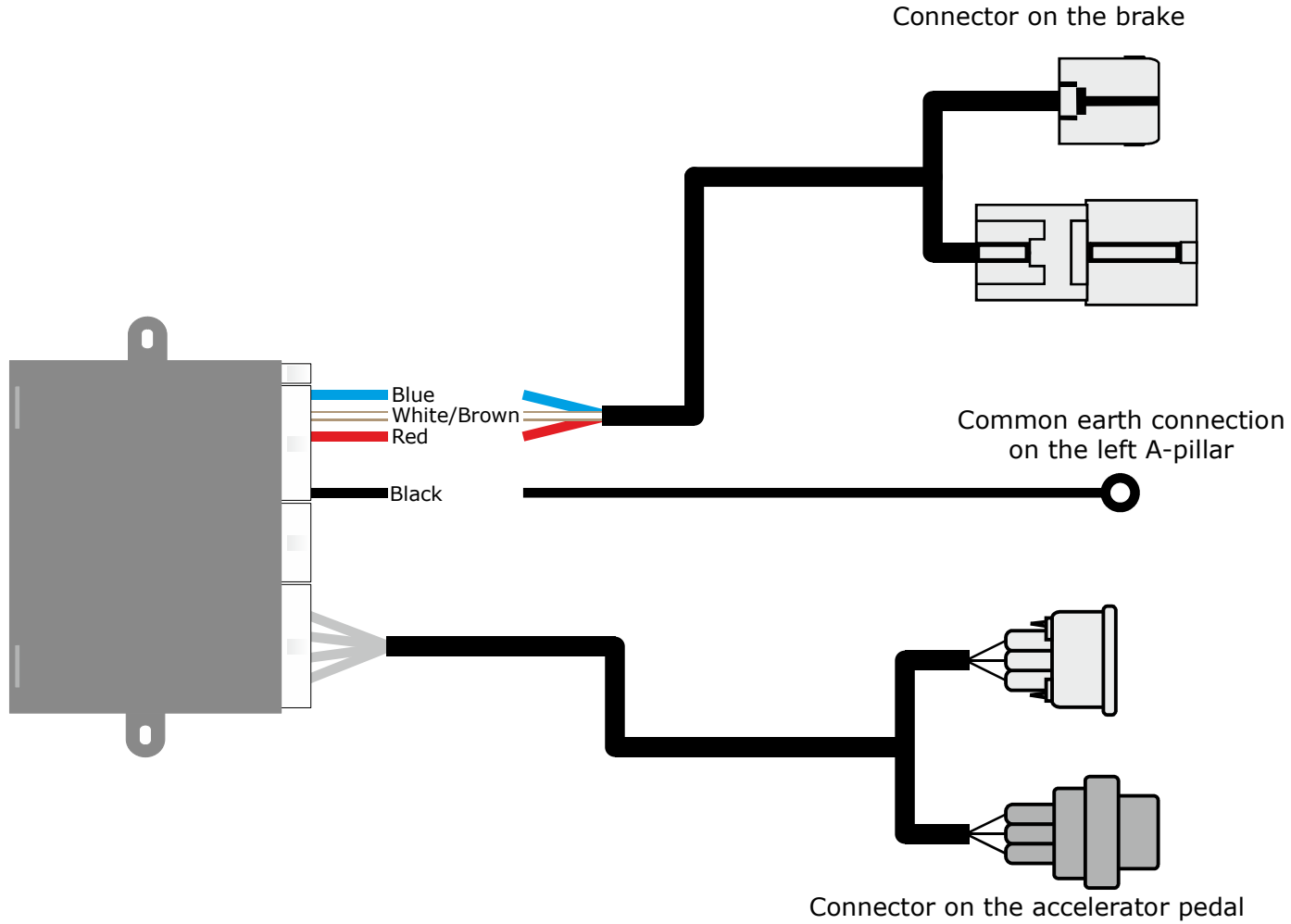

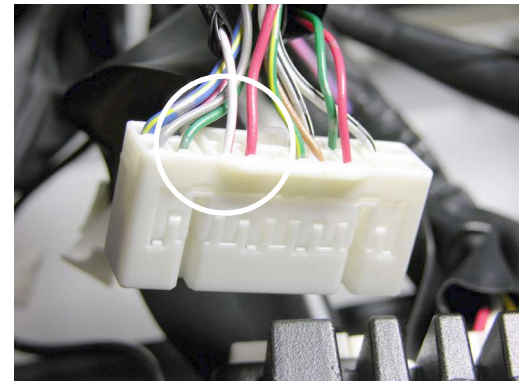
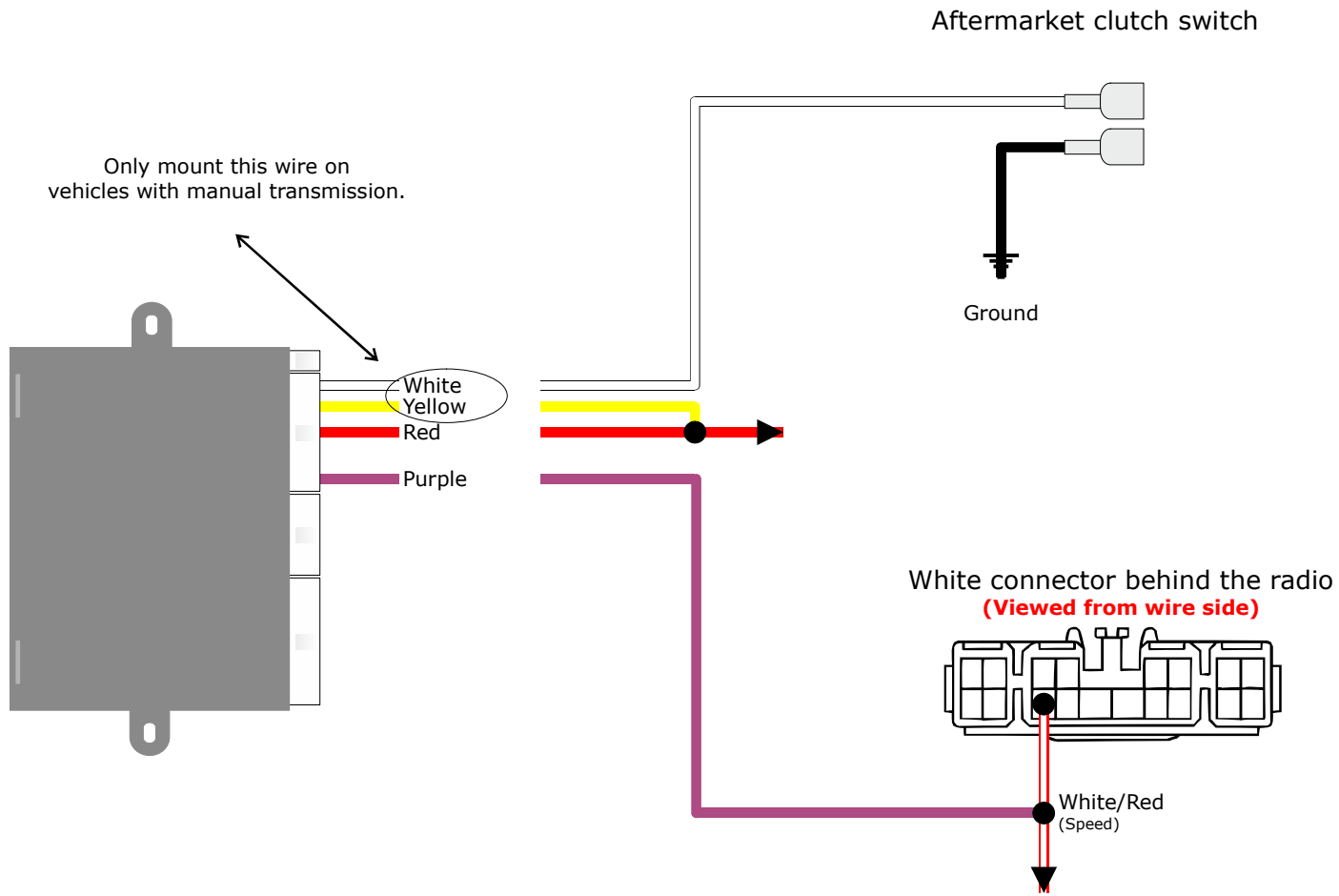

Disconnect the airbag in the manner described by TOYOTA.

Cut the template after the marked line, mount it on the right side of the plastic cover on the steering wheel. Use a 28mm drill.

Mount the connector for the lever in place, and install the lever in the steering wheel with the two enclosed screws.

Cut the two wires of the small 4-p connector, and solder them to the enclosed white wires. Insert the white wires in to the connector behind the airbag connector in pin 7 and 8. Placement is unimportant.

Reinstall the steering wheel and reconnect the airbag.

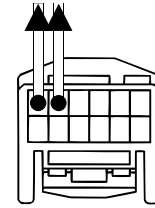
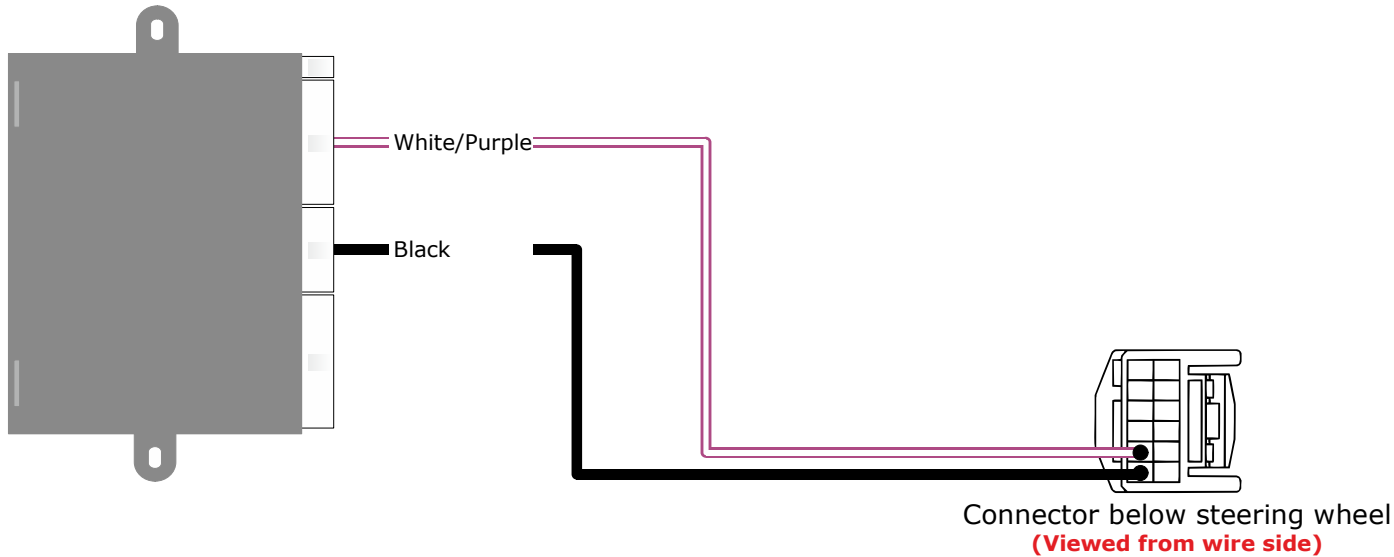

Connector behind the airbag
(Viewed from wire side)

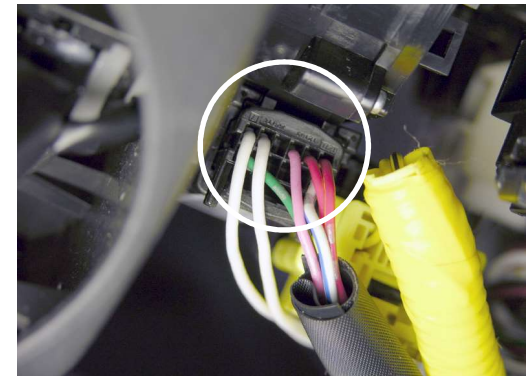

Insert the Black and White/Purple wire in to the connector in pin 7 and 8. Placement is unimportant.

Trouble shooting guide.

Enable Diagnostic mode:



Put ignition on the vehicle

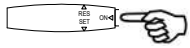

Within 2 seconds, press and hold the ON function



Wait until test LED lights up in RED color



Release ON function



Within 5 seconds

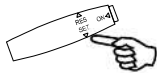

Press and hold SET function



The test LED lights up in ORANGE color



Release SET function



Within 5 seconds

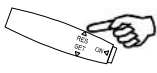

Press RES function



The test LED will flash in all 3 colors, provided that no inputs are activated.
Otherwise the test LED will light up red.

Reaction to the individual tests, requires that the function is active

Test 1 - Brake function. Activate RES briefly. Test LED will flash orange 1 time.

CANbus installation: (No wires mounted on the brake connector).

1. Test LED lights up Red, and changes to green when pedal is depressed.

Analog installation: (Wires mounted on the brake connector).

1. If both brake wires are installed correctly, the test LED will light up green.
2. Hot side of brake is defective = test LED lights up red.
3. Cold side of brake is defective = test LED lights up orange.
4. Both sides of brake defective = test LED flashes all 3 colors.
5. When brake pedal is depressed, the test LED lights up orange.

Test 2 - Clutch function. Activate RES briefly. Test LED will flash orange 2 times.

CANbus installation: (No wires mounted on the clutch connector).

1. Test LED lights up Red, and changes to green when pedal is depressed.

Analog installation: (Wires mounted on the clutch connector).

1. If clutch wires are installed correctly, the test LED lights up green.
2. If clutch is defective, the test LED lights up red.
3. When clutch pedal is depressed, the test LED lights up red.

Test 3 - Accelerator pedal function (engine off). Activate RES briefly. Test LED will flash orange 3 times.

1. The test LED will slowly flash red/green.
2. Depressing the accelerator pedal will increase the freq. of the flashing.

Test 4 - VSS function (engine running). Activate RES briefly. Test LED will flash orange 4 times.

CANbus installation: (Purple wire is not connected).

1. The test LED will flash green if correct ID is received.

Analog installation: (Purple wire is connected).

1. The test LED will flash green when vehicle is moved.

Test 5 - TACHO function (engine running). Activate RES briefly. Test LED will flash orange 5 times.

CANbus installation: (Purple wire is not connected).

1. The test LED will flash green if correct ID is received.

Analog installation: (Purple wire is connected).

1. The test LED will flash green when RPM is raised.

Test 6 - Setup to Automatic gear. Activate RES briefly. Test LED will flash orange 6 times.

(This point should ONLY be performed if it is described on the front page with red text).

1. Activate and hold down the brake pedal.
2. Activate SET briefly = test LED lights up red.
3. Activate SET briefly again = test LED lights up orange. E-Cruise is set for automat gear. If this function is activated by mistake. The test procedure must be entered from start.

Setup to Manual gear.

1. Activate and hold down the brake pedal.
2. Activate SET briefly = test LED lights up green.
3. Activate SET briefly again = test LED lights up orange. E-Cruise is set for manual gear.